

External Floating Roof Mechanical Seals

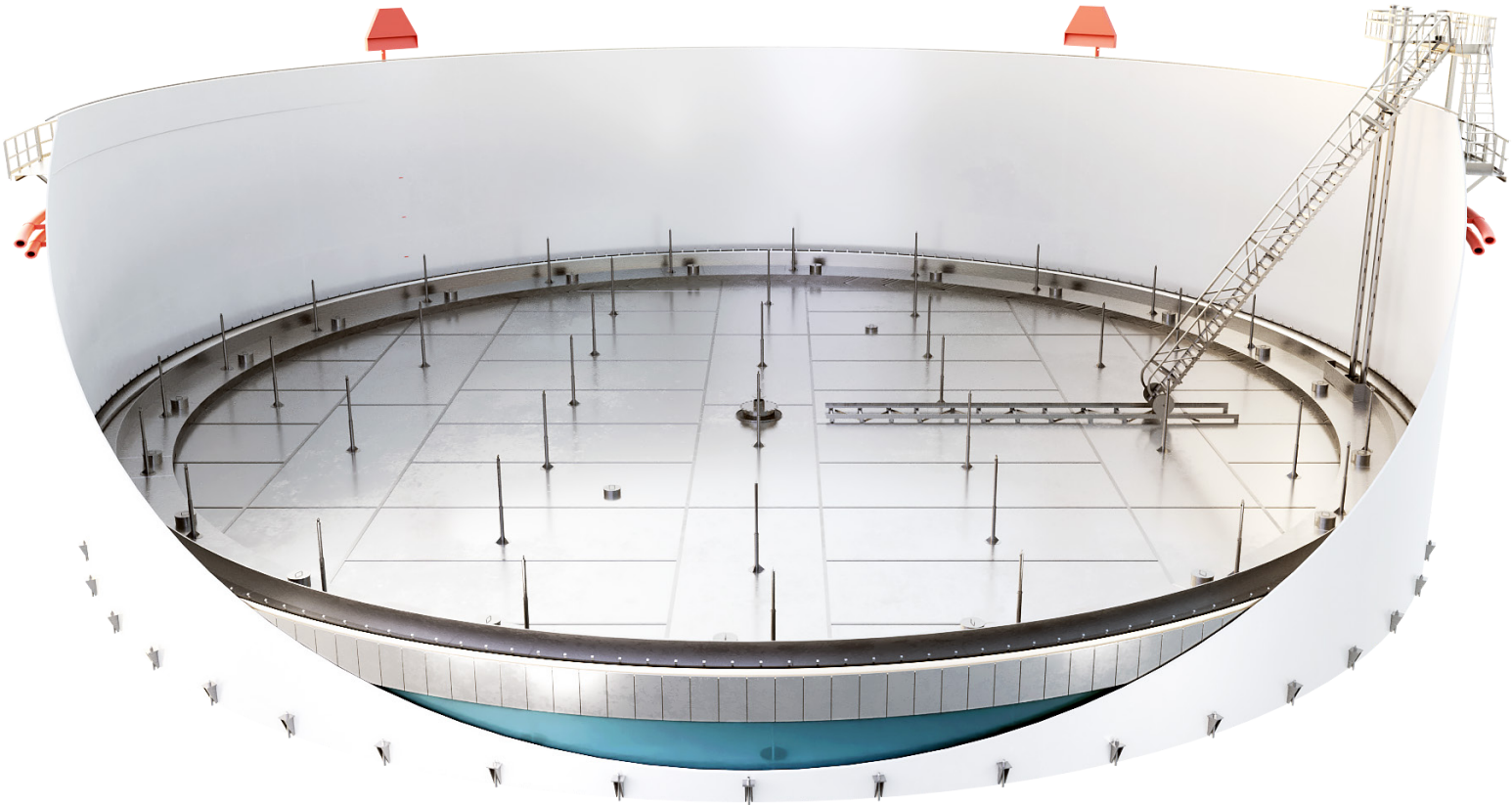

External Floating Roof Mechanical Seals



StorageTech™ Primary Mechanical shoe seal system has been specified according to the type of Storage tank and liquid stored.

The most commonly used sealing systems are vapour emission mechanical shoe seals.

The choice of effective sealing system depends on the products stored and the emission requirements. Corrosion resistivity of the sealing material is directly affected by the liquid stored.

Sealing material has to be chosen according to the chemical resistance compatibility.

Specifying better quality material with low cost in a balance is the most important issue regarding be used the sealing system.

We manufacture all the fasteners and washers used for the installation, including fabric gasket joints, from austenitic stainless steel.

Benefits

- Mechanical seal system is designed to be installed as a bolted seal system and without any hot work such as welding.
- Mechanical shoe seal materials should be determined carefully continuously processes, minimum maintenance requirements as well as stored corrosive liquid
- It is a priority to keep the total weight as light as possible. The shoe seal has been designed to allow for flexibility in installation.
- Full compliance with regulations, including local Air Quality Management District requirements.

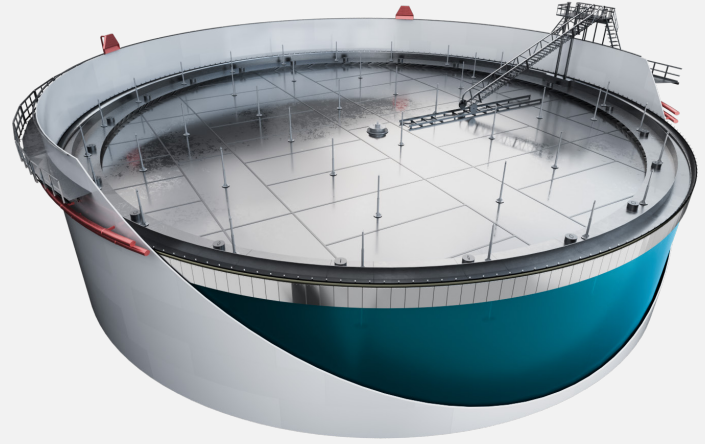

Design Features

Each seal is customized to fit the tank to ensure maximum performance, long life, and safe operation. The shoe is connected to the floating deck by braces and held tightly against the wall by weighted levers as well as springs.

A flexible coated kind of fabrics is suspended from the shoe seal to the floating deck to form a vapor barrier over the annular space between the deck and the primary seal.

StorageTech™ Liquid mounted Primary shoe seals can be categorized as PANTOGRAPH and SCISSOR type seals. The most critical factor affecting the performance of the sealing system is the load applied to the shoe seals.

Fluid Stored	Non-Metallic Seal Material
Crude Oil	Fluoroelastomer based on a Terpolymer of Vinylidene difluoride, VDF/Hexafluoropropylene, HFP/Tetrafluoroethylene, TFE Copolymer of tetra-fluoroethylene and propylene (TFE/P)
Refined Products	Fluoroelastomer based on a Dipolymer of VDF/HFP
Gasoline/ MTBE Blend	Polytetrafluoroethylene(PTFE) laminate
MTBE(100%)	A copolymer of ethylene, tetra-fluoroethylene and perfluoromethylvinyl ether, and a cure site monomer; peroxide cure site
Benzen/ p-Ksilen/ Toluen/ Etil Benzen	Polytetrafluoroethylene(PTFE) laminate , Copolymer of tetra-fluoroethylene and propylene (TFE/P) , Fluoroelastomer based on a Dipolymer of VDF/HFP
Metanol/ Aseton/ Etanol/ Formaldehit	A copolymer of ethylene , Fluoroelastomer based on a Terpolymer of Vinylidene difluoride

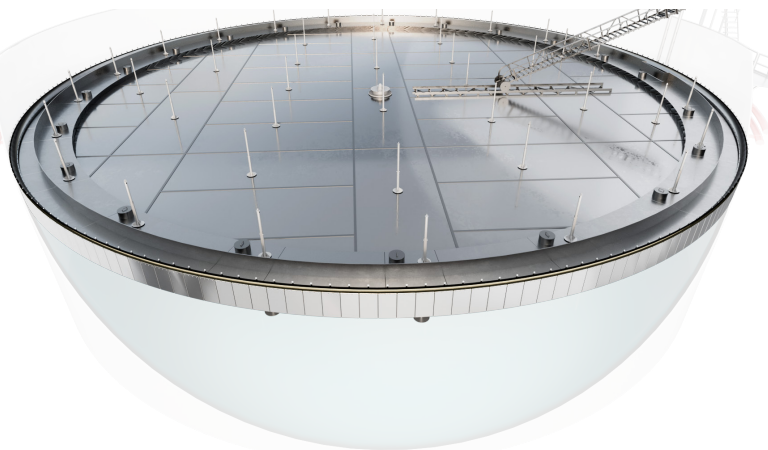

Pantograph Type

Primary Seal

It is the most widely used seal design on floating roof tanks and storing all crude oil and refined oil products.

The load applied by the weights, on the top and bottom of the mechanical seal is maximized.

Mechanical seal type pantograph provides sealing throughout the roof's movement, roof shifts, shape changes, buckling, and the tank's expansion and contraction.

mechanical seal type pantograph, the shoes are available in galvanized (1.5mm thick) and stainless steel (1.2mm thick). Using hardened materials reduces fatigue.

Effective seal performance can cover openings up to 200 mm and it can work with ± 100 mm tolerance.

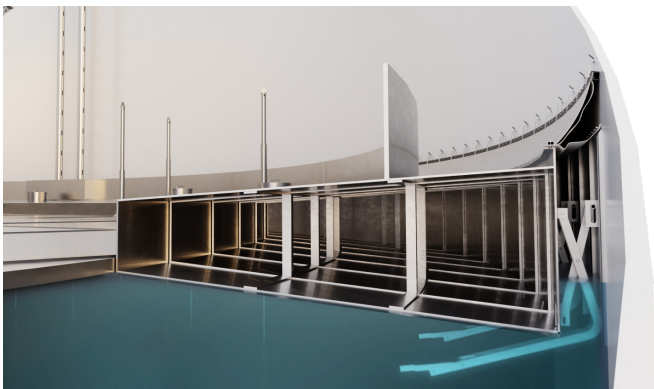

	Part Name	Material	
07	Foam Dam, Thk.3mm	Optional	1/4 Hardened
06	Rim Clamp	S235 (G)	
05	Fabric	Acc. To Material Specification per Liquid stored	
08	Shunt Sheet	SA 240 gr. 304/316 Dual Certificate	1/4 Hardened
04	Braces		
03	Rim Clip		
02	Shoe Bracket	S235 (G)	1/4 Hardened
01	Shoe Plate		

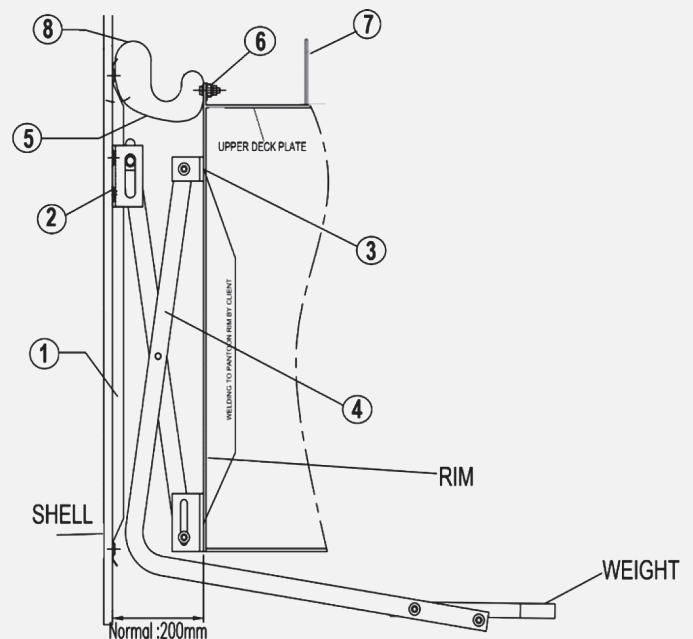

Pantograph Type

Primary Seal & Secondary Seal

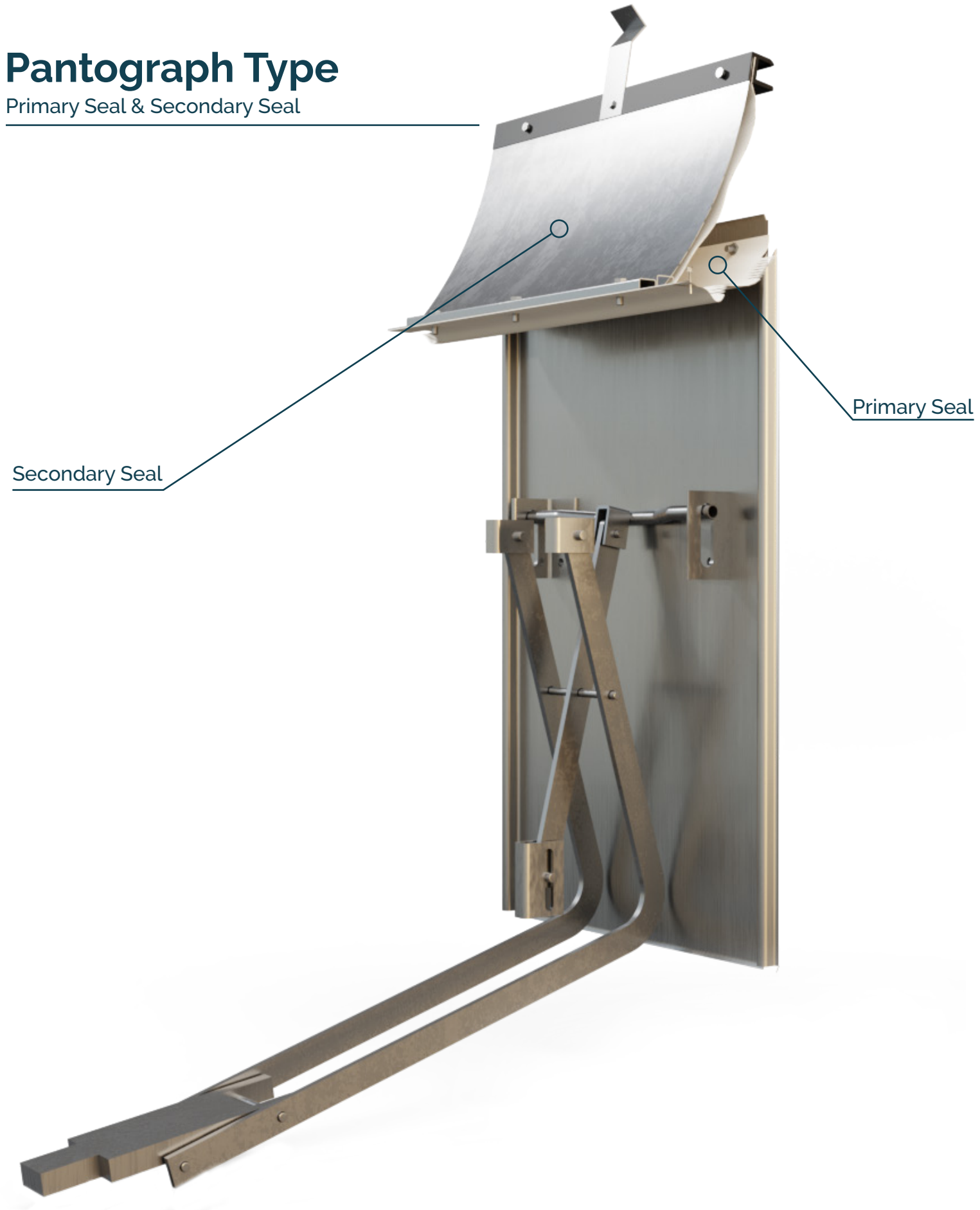

Secondary Seal

Primary Seal

Scissor Type

Primary Seal

The most important case in the usage of this type sealing is to increase the material strength by reducing the weight and to ensure the sealing of, especially light and corrosive storage products.

Tensioners are attached to the top and bottom of the shoe. This keeps the entire width of the shoe in contact with the tank shell and important for wax scraper designs.

If there is a corrosive load inside the tank, we recommend using mechanical seal scissor.

The materials used are thinner than Carbon steel and Aluminum as well as the usage of additional weight is not required, the system minimizes product escape with the effective load provided by the springs, unlike the weighted system.

Its spring system, it successfully meets 200 mm rim width and works effectively maximum ± 100 mm tolerance in range.

At StorageTech™, we are committed to providing our valued customers with the best product at the best value for corrosive, volatile or light storage products.



	Part Name	Material	
09	Foam Dam, Thk.3mm	Optional	1/4 Hardened
08	Rim Clamp	S235 (G)	
07	Fabric	Acc. To Material Specification per Liquid stored	
11	Shunt Sheet	SA 240 gr. 304/316 Dual Certificate	1/4 Hardened
10	Balance Spring		
06	Spacer Plate Scissor		
05	Rim Scissor		
04	Spring		
03	Rim Clip	S235 (G)	1/4 Hardened
02	Shoe Bracket		
01	Shoe Plate		

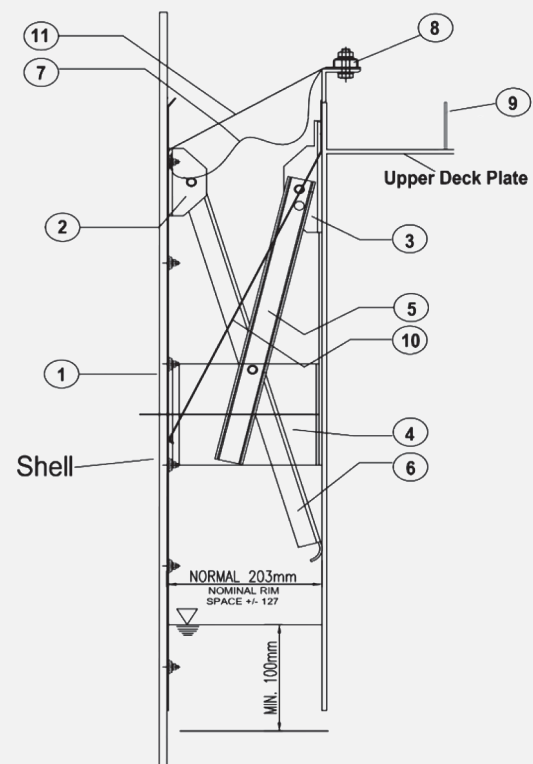

Scissors Type

Primary Seal & Secondary Seal

Secondary Seal



Primary Seal

Wiper Seal

Secondary Seal

The secondary seal serves as a supplementary layer, Capacity the vapor containment capability of the external floating roof system. The secondary seal is mounted on the edge of the floating roof, bridging the gap between the roof and the tank wall.

Its purpose is to create a secondary barrier that further restricts the release of vapours into the atmosphere, even in the event of minor gaps or failures in the primary seal.

As a secondary seal, with a weather shield and Teflon cover, it protects the tank from UV, dust, dirt, and rain.

The seal material resists corrosion and can be made from various materials based on what is stored. The choice of sealing products highly depends on corrosive environment needs. It can include alloyed steel parts to increase corrosion resistance as needed.

The system is grounded by the shunt parts to prevent electrical arc that can occur due to static electricity on entire system.

Installation is simple and safe.

All connections are bolted. No hot works such as welding will be required during installation.

In accordance with the API650 standards for the design of our secondary gasket, it is possible to examine the primary gasket without the need for removal.

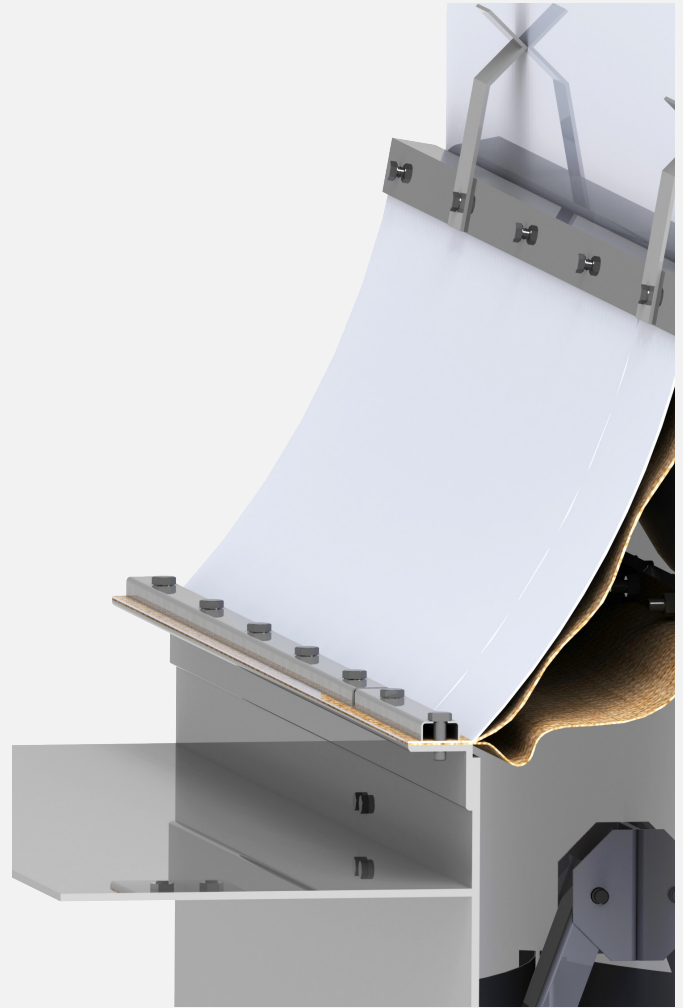

	Part Name	Material
11	Tape Gasket, Rubber Foam	Acc. To Material Specification per Liquid stored
07	Lip Seal	
06	Vapour Barrier	
10	SQ Nut	SA 240 gr. 304/316 Dual Certificate
09	Special Washer	
08	Stove Bolt	
05	Earthing Shunt	
04	Hex Bolt & Nut with 2 Nos. Washer Lock Washer + 2x Large Washer	
03	Hex Bolt & Nut With 2 Nos. Washer	
02	Clamping Channel	
01	Compression Plate	S235 (G)

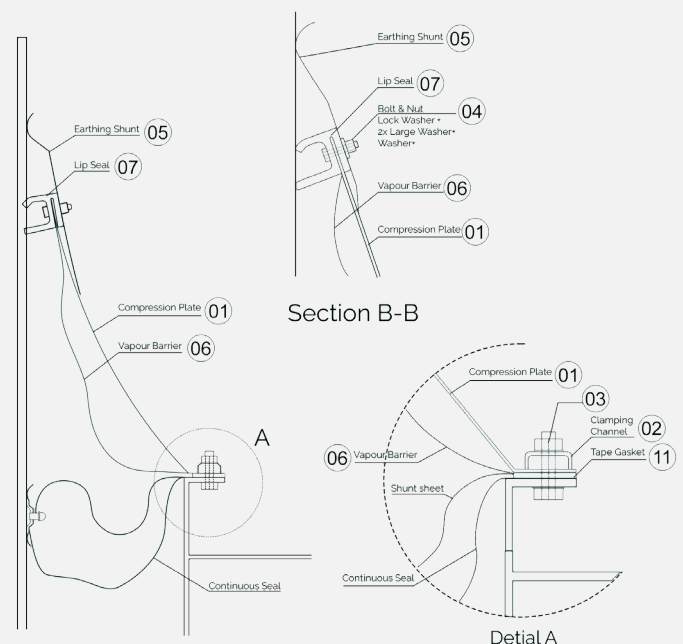

Äger GmbH

Germany Head Office + R&D + Sales
Herzogspitalstraße 24
Munich 80331
Germany
+49 (0) 89 1250 15240
www.aager.de
sales@aager.de

Turkey Head Office + Sales
Ağaoğlu My Office 212
No: 3 B Blok /175
P.K 34218 Güneşli – Bağcılar
Istanbul / Turkey
+90 212 485 40 07
+90 212 485 40 42
sales@aager.de

Turkey Factory + Engineering + R&D
+ Sales
Mersin Tarsus OSB.13.CD.NO:7
P.K: 33540 Mersin, Turkey
+90 324 676 44 04
+90 324 676 44 03
sales@aager.de

U.A.E. Sales + Warehouse
Jumeirah Lake Towers, X2 Tower 1906
P.O. Box: 123661 Dubai, U.A.E.
+971 4 450 8051
+971 4 450 8041
sales@aager.de

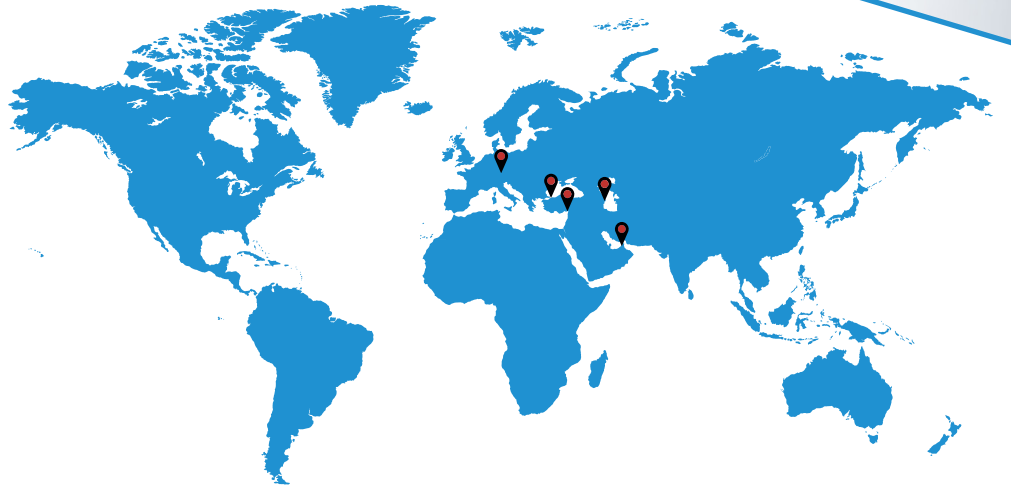

data sheet series

**External Floating
Roof Seals**

Revision No: 02
ST-DS-EFRS-06.24/V2
storagetech.de

Storagetech™ Website
QR Code



June 2024



