

# Flame Arrester

Horizontal, in-line, detonation



## Model 321

### Product Description

Storagetech™ Model 321 In-line Detonation Flame Arrester is designed for installation in gas pipelines. Detonation occurs when a flame travelling through the pipeline reaches supersonic velocities, usually as a result of the pipeline configuration or pipeline surface roughness. Changes in gas density and pressure causes the flame velocity to metamorphose from subsonic to supersonic.

The flame quenching element is designed to be three or four times the area of the pipe in which it is installed, and is assembled between two angled reducing spools.

Flame Arresters are designed to effectively prevent the passage of flame. StorageTech Flame Arresters consist of flame arrester disks made of coiled, corrugated metal strips, spacers and a housing.

They are typically mounted to a flange or pipe, which connects the vapor space of a storage tank or a pipeline.

ERGIL Storagetech™ Model 321 In-line Detonation Flame Arrester has a maximum experimental safe gap (MESG) as per the standard, and is suitable for gas groups IIB and IIA. The detonation flame arrester is more robust than the deflagration flame arrester, and contiguous scrolls have smaller MESG's to withstand higher pressures and to quench detonations. It should be installed in the pipeline where there is a significant distance between the unit and the potential source of ignition.



StorageTech provides the high quality and reliable solutions for your needs with 40 years of experience.

Your investments will be much safer with Storagetech™ Flame Arrester solutions, which are completely produced in accordance with international norms.



<b>Standard Sizes</b>	4"(IIA) / 2" to 12"( IIB)ø
<b>Body / Flanges</b>	1- Carbon steel 2- Stainless steel AISI 304 -L or 316-L 3- Aluminium 4- Customer Specification
<b>Flange Drilling</b>	ANSI #150, PN16, and Special
<b>Flame Element</b>	Stainless steel AISI 304 -L or 316-L
<b>Gasket</b>	PTFE, Nitrile, Viton, Special
<b>Screen</b>	SS 304
<b>Paint Finish</b>	1- Powder Coating, Colour RAL 9006 2- Epoxy Paint, Colour RAL 9006 3- Customer Specification
<b>ATEX Cert</b>	Ex II 1/2 G IIA , G IIB

## In Line Detonation Flame Arresters

- Under normal operation the flame element allows the bidirectional flow of air and flammable vapour, however it introduces additional pressure loss, and this must be considered in the design of the system. If a fire or ignition occurs external to the equipment and ignites the flammable discharge, the flame arrester will quench the leading fire by absorbing and dispersing the heat as it passes through the element.
- Stop the shock waves and controls the flashback explosions.

## Design & Manufacturing Specifications



The size of the vent will be calculated in accordance with API Standard 2000 - Venting Atmospheric and Low-Pressure Storage Tanks or other international standards.

## Standard Compliance

In-Line Deflagration Flame Arresters has been type-tested to EN ISO 16852 and approved according to ATEX Directive 2014/34/EU.

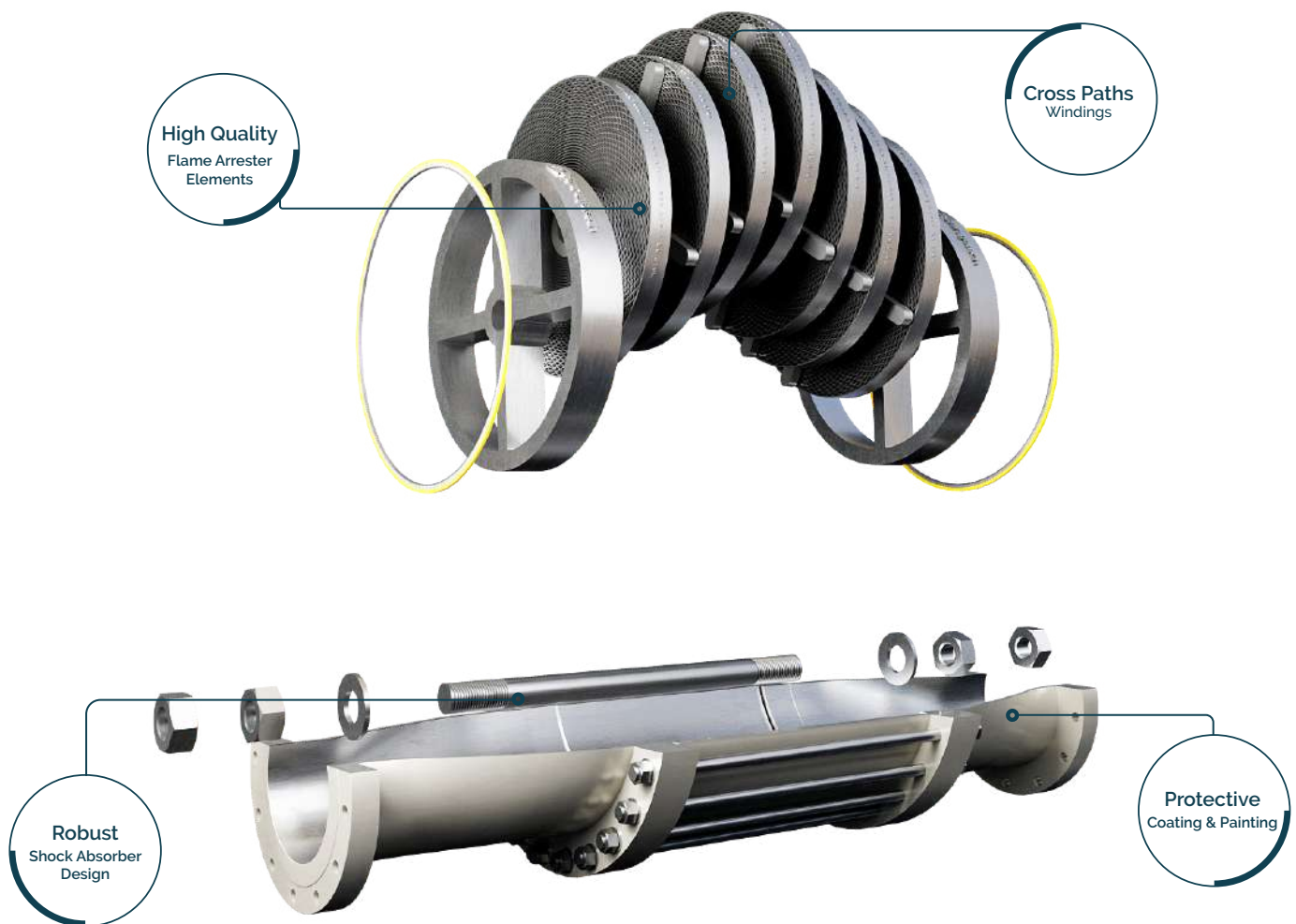

## Key Features

- StorageTech™ PW Model 301 internal materials are AISI 316 or 304 stainless steel.
- Easy to clean internal materials.
- Easy to install. You do not need a special tool or experience to install the StorageTech Flame Arrester Model 300.
- StorageTech™ PVV Model 301 comes with the paint color you choose.
- Standard manufacturing comes with API 150 class flange; however other flange types are available on request.
- Protection cap is manufactured from aluminum material.

## Product Benefits

StorageTech™ Flame Arrester Model 321 provides safety. It blocks the flame and does not allow flame travel through a pipeline or any in outlet. Protects environment. Flame arrester prevents your facility against fire that is caused by explosions.

The area of each passage determines level of protection that the element provides. StorageTech™ Model 321 Inline Deflagration Flame Arrester has a Maximum Experimental Safe Gap as per standard, and is suitable for gas groups IIB and IIA.

Flame arresters are usually designed for use at ambient temperature and pressure. Please consult StorageTech experienced and trained engineers for advice if other conditions are encountered. Higher temperatures and pressures put increased load on the flame arrester and testing under actual or simulated conditions may be required.

Regular inspection and maintenance of flame arresters is essential. If a flashback is known or believed to have occurred then the arrester should be inspected for damage. Small cells or components of the flame arrester are prone to dirt collection and clogging, leading to increased pressure drop.

Damaged or dirty elements should be replaced. It is usually possible to clean the element for reuse. When properly maintained, a flame arrester can provide many years of service.

## Unconfined Deflagration

Unconfined deflagration is caused by the ignition of a flammable gas outside a container or equipment. For example, vent gas from a gasoline tank can create a cloud of flammable vapor around it. A lit cigarette, static electricity or lightning can ignite this vapor and the resulting flame can return to the tank.

## Confined Deflagration

When a flammable mixture in a pipeline is ignited, the flame front initially travels along the pipe at subsonic speeds, a phenomenon called confined deflagration. For example, methane gas produced in underground coal mines is transported to the surface through a pipe and burned in a boiler. However, a malfunction in the boiler or pumping system can ignite the gas in the pipe and the flame can travel along the pipe and explode the gas underground.

## Detonation

The detonation occurs at the point where the flame travels along a pipe at supersonic speeds and merges with the shock wave. This is usually caused by interruptions in the pipe that create turbulence, such as roughness, bends, valves or cross-sectional changes. It can also occur if the flame is allowed to accelerate a sufficient distance along the pipe. The shock wave is characterized by a change in pressure and density where the flame velocity changes from subsonic to supersonic.



## In-line with Weco Connection Detonation

Depending on the purpose of use in the field, connection types in flame arresters can be provided with hammer unions to meet the needs of pipelines.

With these fasteners, which are used in areas where fast plug-in applications are required during operation, the maintenance of flame arresters on the relevant lines can be carried out without requiring any additional connection materials.

The oil and gas sector uses WECO couplings, also known as HAMMER LUG unions, to quickly connect pipes and flexible hose assemblies.

No additional equipment are required to tighten and loosen HAMMER LUG unions—just a hammer, as the name implies.

The components of a HAMMER LUG union are a coupler with an inner cone and a male thread, a ball-shaped fitting with a male half and a female thread nut that secures the ball-shaped fitting to the coupler's cone. Depending on the kind, a primary sealing (metal/metal) is performed by a tight contact of the ball end with the cone, or the sealing is accomplished by a second rubber seal (o-ring or lip seal).

The coupling's (the nut and coupler's) trapezoidal ACME thread is included (standard or modified). They either weld in connections or connect to an installation using NPT female thread end connectors.



The following pertinent industry standards are met or exceeded by all union products: **NACE, ISO, DNV, API, ASTM A-105, ASTM A29, ASTM A536 Grade 65-45-12, and ASME B1.20.1.**

Hammer Unions are used to join heavy-duty, high-pressure flow lines. They may frequently be found in strip mines, chemical factories, maritime dredging vessels, and the oil sector (depending on model, for sand slurry, oil, water, steam, etc).



## Technical Drawing

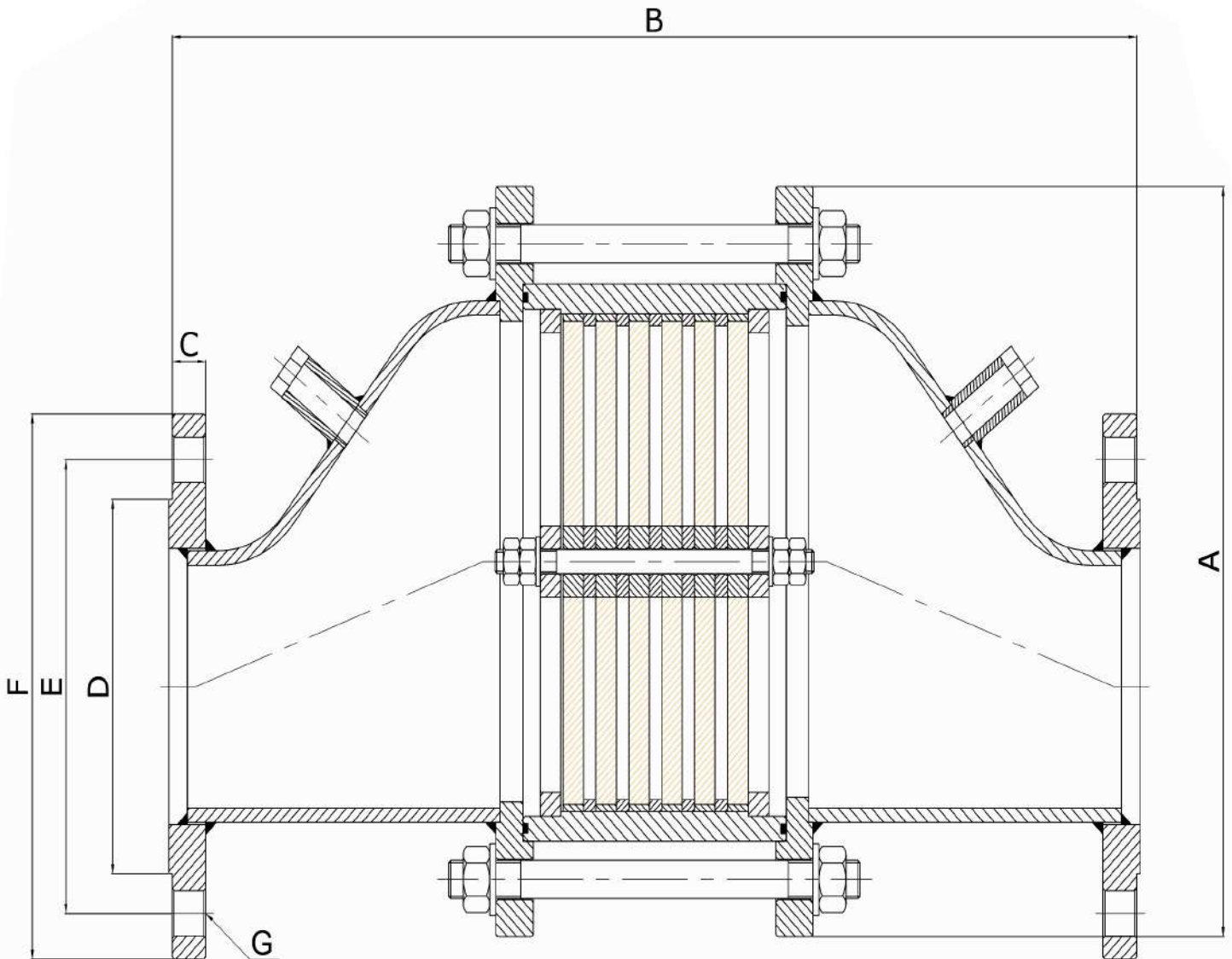

## Weight & Dimensions

SIZE	A	B	C	D		E		F		G		TOTAL WEIGHT (kg)				
				ANSI 150# RF	PN 16	ANSI 150# RF	PN 16	ANSI 150# RF	PN 16	ANSI 150# RF	PN 16	WELDED		CASTING		
NPS DN												CS	SS	AL	CS	SS
2" 50	254	725	18	92	102	120.6	125	152	165	Ø19x4	Ø18x4	34-41	34-41	12-17	34-48	34-48
2 2/1" 65	279	820	18	104	122	120.6	125	140	145	Ø19x4	Ø18x8	51-62	51-62	18-25	51-72	51-72
3" 80	318	846	18	127	138	152.4	160	190	200	Ø19x4	Ø18x8	69-80	69-80	23-29	75-88	75-88
4" 100	381	895	18	157.2	158	190.5	180	229	220	Ø19x8	Ø18x8	90-100	90-100	42-48	92-104	92-104
6" 150	505	926	18	216	212	241.3	240	279	285	Ø22x8	Ø22x8	111-122	111-122	59-67	144-162	144-162
8" 200	580	872	18	270	268	298.4	295	343	340	Ø22x8	Ø22x12	115-125	115-130	46-52	120-140	120-140
10" 250	697	1052	22	324	320	362	355	406	405	Ø25.4x12	Ø26x12	170-190	170-190	100-120	230-270	230-270
12" 300	860	1162	22	381	378	431.8	410	483	460	Ø25.4x12	Ø26x12	325-420	325-420	240-270	525-585	525-585

<b>A</b>	•Element Diameter
A-H	•Element Height
<b>B</b>	•Element Housing Diameter
B-H	•Element Housing Height
<b>C</b>	•Element Holder Diameter
C-H	•Element Holder Height
<b>D</b>	•Spacer Diameter
D-H	•Spacer Height

MODEL	IIB DETONATION - MODEL 320						
SIZE	2"	3"	4"	6"	8"	10"	12"
<b>A</b>	100	200	250	300	400	500	600
A-H	10	10	10	10	10	15	15
<b>B</b>	150	250	300	350	500	600	700
B-H	90	90	90	100	100	200	200
<b>C</b>	150	200	250	300	450	550	600
C-H	10	10	10	20	20	20	20
<b>D</b>	100	200	250	300	400	500	600
D-H	6	6	6	6	6	6	6

### Flow Capacity Tables Pressure Drops (mbar)

Gas Group	Element	Pipe Size	Flow in Nm <sup>3</sup> /h Air																				
			5	10	15	20	30	40	50	60	70	80	90	100	150	200	300	400	500				
IIB	118/30/35	DN50	2"	<0.5	<0.5	<0.5	<0.5	<0.5	<0.5	<0.5	<0.5	0.7	1.2	1.5	2	2.4	4.6	9.7	20.9	37.8	60.1		
	135/30/35	DN65	2.5"	<0.5	<0.5	<0.5	<0.5	<0.5	<0.5	<0.5	<0.5	0.5	0.9	1.1	1.4	2.8	5.7	12.8	23.2	36.3			
	175/30/35	DN80	3"	<0.5	<0.5	<0.5	<0.5	<0.5	<0.5	<0.5	<0.5	<0.5	<0.5	<0.5	0.5	1	1.9	3.7	7.6	12.1			
	223/30/35	DN100	4"	<0.5	<0.5	<0.5	<0.5	<0.5	<0.5	<0.5	<0.5	<0.5	<0.5	<0.5	<0.5	<0.5	<0.5	0.7	1.6	2.9	4.6		
	267/30/50	DN160	6"	<0.5	<0.5	<0.5	<0.5	<0.5	<0.5	<0.5	<0.5	<0.5	<0.5	<0.5	<0.5	<0.5	<0.5	<0.5	<0.5	<0.5	<0.5	0.7	
	416/30/50	DN200	8"	<0.5	<0.5	<0.5	<0.5	<0.5	<0.5	<0.5	<0.5	<0.5	<0.5	<0.5	<0.5	<0.5	<0.5	<0.5	<0.5	<0.5	<0.5	<0.5	<0.5
	520/30/50	DN250	10"	<0.5	<0.5	<0.5	<0.5	<0.5	<0.5	<0.5	<0.5	<0.5	<0.5	<0.5	<0.5	<0.5	<0.5	<0.5	<0.5	<0.5	<0.5	<0.5	<0.5
	614/30/50	DN300	12"	<0.5	<0.5	<0.5	<0.5	<0.5	<0.5	<0.5	<0.5	<0.5	<0.5	<0.5	<0.5	<0.5	<0.5	<0.5	<0.5	<0.5	<0.5	<0.5	<0.5

Gas Group	Element	Pipe Size	Flow in Nm <sup>3</sup> /h Air																					
			600	700	800	900	1000	2000	3000	4000	5000	6000	7000	8000	9000	10000	12000	16000	18000					
IIB	118/30/35	DN50	2"	87.6	121.3	161.7	207.4																	
	135/30/35	DN65	2.5"	52.4	70.9	93.4	119.2	148.8																
	175/30/35	DN80	3"	17.5	24.4	31.7	40.8	50.3	215.5															
	223/30/35	DN100	4"	6.8	9.5	12.1	15.5	19.8	76.1	177.8														
	267/30/50	DN150	6"	1.2	1.7	2.1	2.8	3.4	13.1	30.3	53.2	84.4	122.7	171.4										
	416/30/50	DN200	8"	<0.5	<0.5	<0.5	<0.5	0.7	2.6	7.1	12.3	18.7	27.2	38.1	48.8	63.1	88.2	113.8	215.6					
	520/30/50	DN250	10"	<0.5	<0.5	<0.5	<0.5	<0.5	0.9	2.9	5.2	7.7	11.3	14.7	20.2	24.8	31.4	45.5	81.2	103.4				
	614/30/50	DN300	12"	<0.5	<0.5	<0.5	<0.5	<0.5	0.5	1.4	3.1	4.4	6.3	8.2	10.1	13.4	15.8	23.4	40.8	52.1				

## Flow Capacity Curves

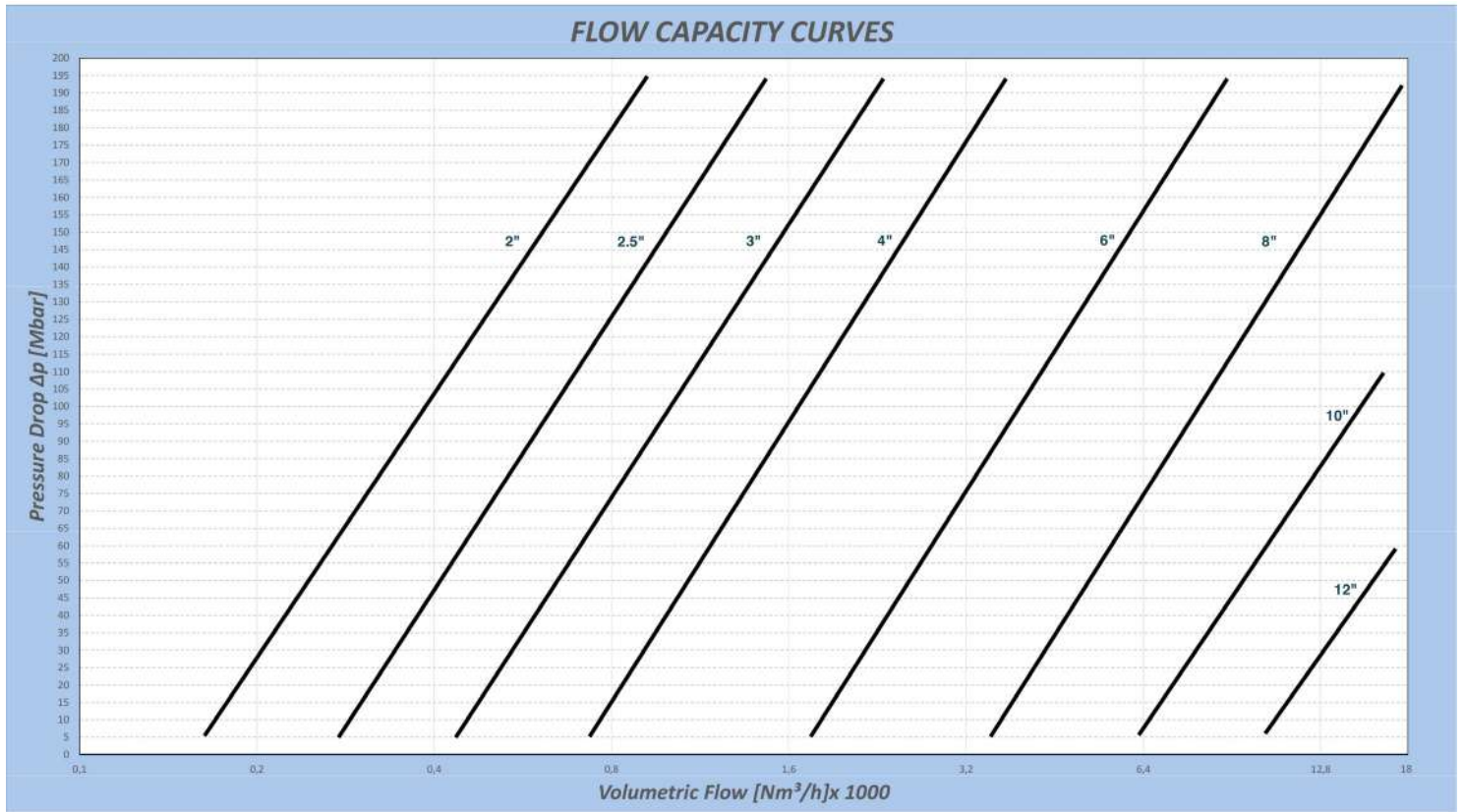

# Product Recommendations

Storagetech™ manufactures storage tank equipment, such as flame arresters, breather valves, gauge hatches, floating roofs, and floating suction pipe.



## Flame Arrester

End-Of-Line,  
With Automatic  
Opening Hood,  
Deflagration

Model: 312

Storagetech™ Flame Arrestors (End-of-line, with Automatic Opening Hood) are passive devices that prevent the propagation of a flame or fire from entering into an opening in a pipeline or vessel discharging flammable vapor. As different from model 310, Model 312 end of line flame arrester's weather hood is designed to react fire instantly tanks to its fusible link, which is melted during the fire and let the weather hood release the gas/fire to the atmosphere.



## Pressure Vacuum Relief Valve With Flame Arrester

End-Of-Line,  
Weight Loaded,  
Combination,  
Atmospheric Deflagration  
Proof

Model: 330

Storagetech™'s Model 330 Pressure Vacuum Relief Valve with Flame Arrester provides protection to bulk storage tanks and vessels from over and under pressurization.



## Flame Arrester

Vertical,  
In-Line,  
Detonation

Model: 320

Storagetech™'s Model 320 In-line Detonation Flame Arrester (also called flame arrester or fire arrester) is designed for installation in gas pipelines. Detonation occurs when a flame travelling through the pipeline reaches supersonic velocities, usually as a result of the pipeline configuration or pipeline surface roughness. Changes in gas density and pressure causes the flame velocity to metamorphose from subsonic to supersonic.



## Flame Arrester

Vertical,  
In-Line,  
Deflagration

Model: 300

Storagetech™'s Model 300 Vertical In-line Deflagration Flame Arrester (also called flame arrester or fire arrester) is intended for pipeline installation close to the source of any potential ignition source by minimising flame speed and the development of an explosive pressure.



## Äger GmbH

Germany Head Office + R&D + Sales  
Herzogspitalstraße 24  
Munich 80331  
Germany  
+49 (0) 89 1250 15240  
www.aager.de  
sales@aager.de

Turkey Head Office + Sales  
Ağaoğlu My Office 212  
No: 3 B Blok /175  
PK 34218 Güneşli – Bağcılar  
Istanbul / Turkey  
+90 212 485 40 07  
+90 212 485 40 42  
sales@aager.de  
sales@storagetech.de

Turkey Factory + Engineering + R&D + Sales  
Mersin Tarsus OSB.13.CD.NO:7  
PK: 33540 Mersin, Turkey  
+90 324 676 44 04  
+90 324 676 44 03  
sales@aager.de  
sales@storagetech.de

UAE Sales + Warehouse  
Jumeirah Lake Towers, X2 Tower 1906  
P.O. Box: 123661 Dubai, UAE  
+971 4 450 8051  
+971 4 450 8041  
sales@storagetech.de

KSA Sales + Warehouse  
Q1-14, The Business Quarter,  
King Faisal Road,  
Al Khalidiyyah Al Janubiyah,  
Dammam, KSA  
+966138163471  
sales@storagetech.de



### data sheet

Flame Arrester  
Horizontal, in-line, det.

Revision No: 03  
ST-DS-FA.HDT-04.25/V3  
storagetech.de



April 2025

