

Pressure Vacuum Relief Valve

Top mounted, End of Line, Weight Loaded

Model No : 100



Storagetech™'s Model 100 Top Mounted, End of Line, Weight Loaded Pressure Vacuum Relief Valve is designed to protect the tank from excessive internal pressure during operation.

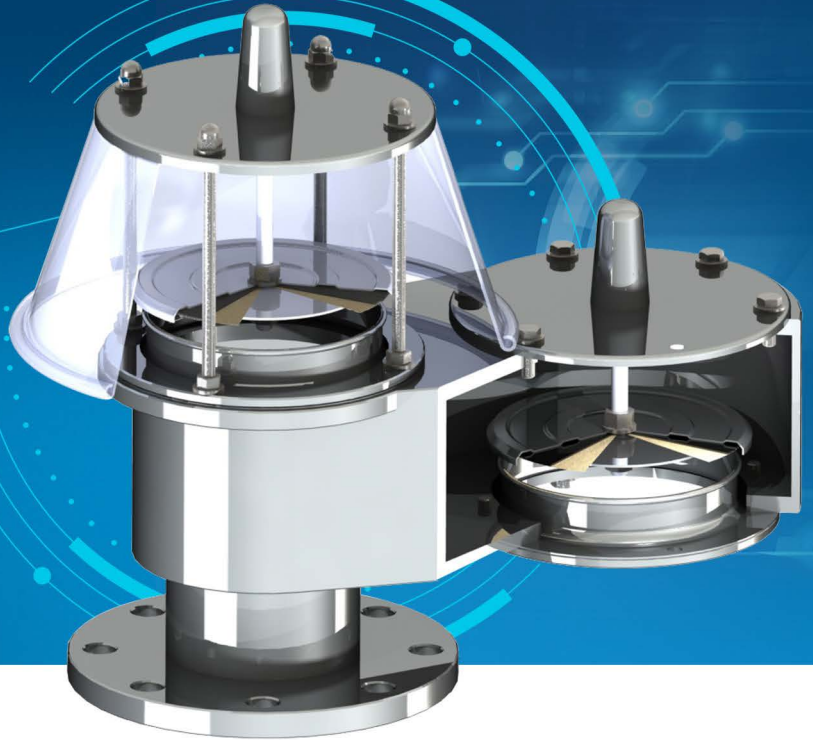

Product Description

Storagetech™'s Model 100 Top Mounted, End of Line, Weight Loaded Pressure Vacuum Relief Valve is designed to protect the tank from excessive internal pressure during operation. The weighted-loaded pallet and diaphragm assembly is held tightly against a seal to prevent the loss of vapour to atmosphere in the closed position. As the internal pressure in the tank increases, due to product filling or vapour development, the set pressure is reached, accordingly, the diaphragm shall be opened and discharge the gas to atmosphere. Model 100 set pressure can be arranged as per storage tank requirements and the valve will reseal when internal pressure returns to below set pressure. The vacuum pallet and diaphragm assembly is similarly maintained in the closed position. As the internal pressure in the tank reduces, due to emptying vacuum conditions occurs, the balance between the tank pressure and the external atmospheric pressure changes. Accordingly when the set pressure of the unit is reached, the diaphragm opens to vacuum air content and rebalance the internal pressure. Storagetech Valves Activated as close as to set pressures, less than 10% of set pressures, ensuring accurate pressure management and isolate emission losses perfectly.

Key Features

- Easy to install. Do not need a special tool or experience.
- Light weight construction
- Quick and easy to install, inspect and clean
- Any grade materials are available.
- Has stainless steel pallets
- Large weatherhood provides maximum airflow
- Internal materials are resistant to winter conditions.
- Special designs can be achievable upon request to meet individual specifications
- Vacuum and relief cases can be managed effectively as per the set requirements of bulk storage tank.
- Super Duo technology provides extra curves and perfect seating with zero leakage.
- Set values can be arranged as per the site conditions, no need supervising.
- Diaphragm is manufactured from PTFE material to prevent possibility of ice formation and sticky residues hindering the valve from opening, while the pallet assembly moves freely on guide posts.
- Design, manufacturing and test according to EN ISO 80079-36.
- Breathing requirements are fulfilled according to API 2000 7th Edition.
- PTFE, XYLAN, Rubber lining, etc. coating options are available.

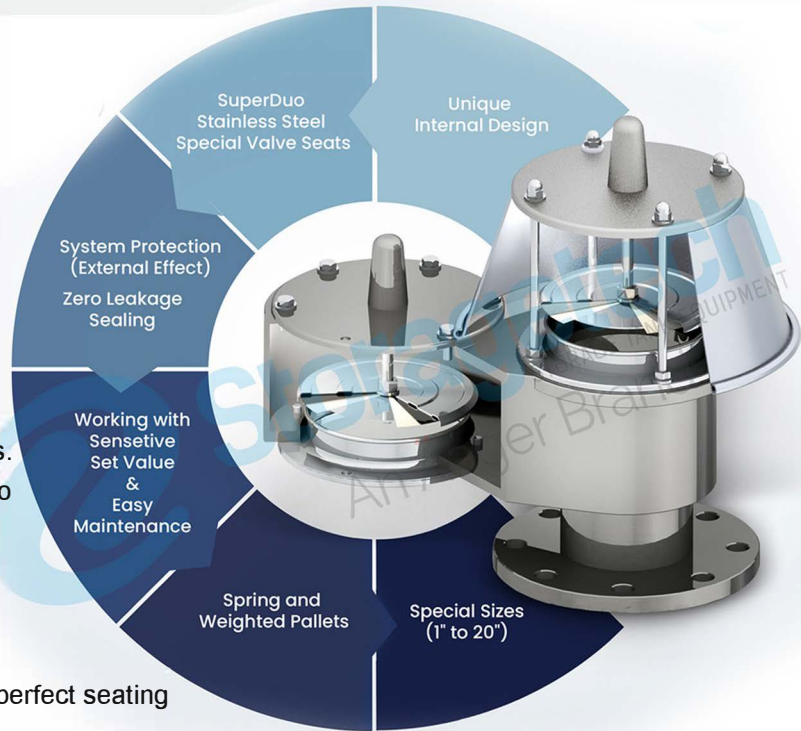

Setting Range

Pressure Weight-loaded ± 2.5 mbar and ± 35 mbar. (± 1 inch W.C and ± 14 inch W.C)

**Different settings can be applicable as per request*

Ambient temp. -20°C to $+60^{\circ}\text{C}$

Construction

Standard Sizes	2" to 12" (DN50 to DN300) - Further sizes are applicable upon request.
Flanges	ANSI, DIN, JIS, BSP
Body	Carbon Steel, Stainless Steel or Aluminium
Seals	Klingrit, Nitrile, Viton, PTFE
Pallet	Stainless Steel AISI 304/316
Springs	Stainless Steel
Paint finish	1.Customer Specification 2.Powder Coating, Colour RAL 9006 3.Epoxy Paint, Colour RAL 9006 4. PTFE Coating
ATEX Cert.	Ex II 1/2 G c II B

Weight and Dimensions

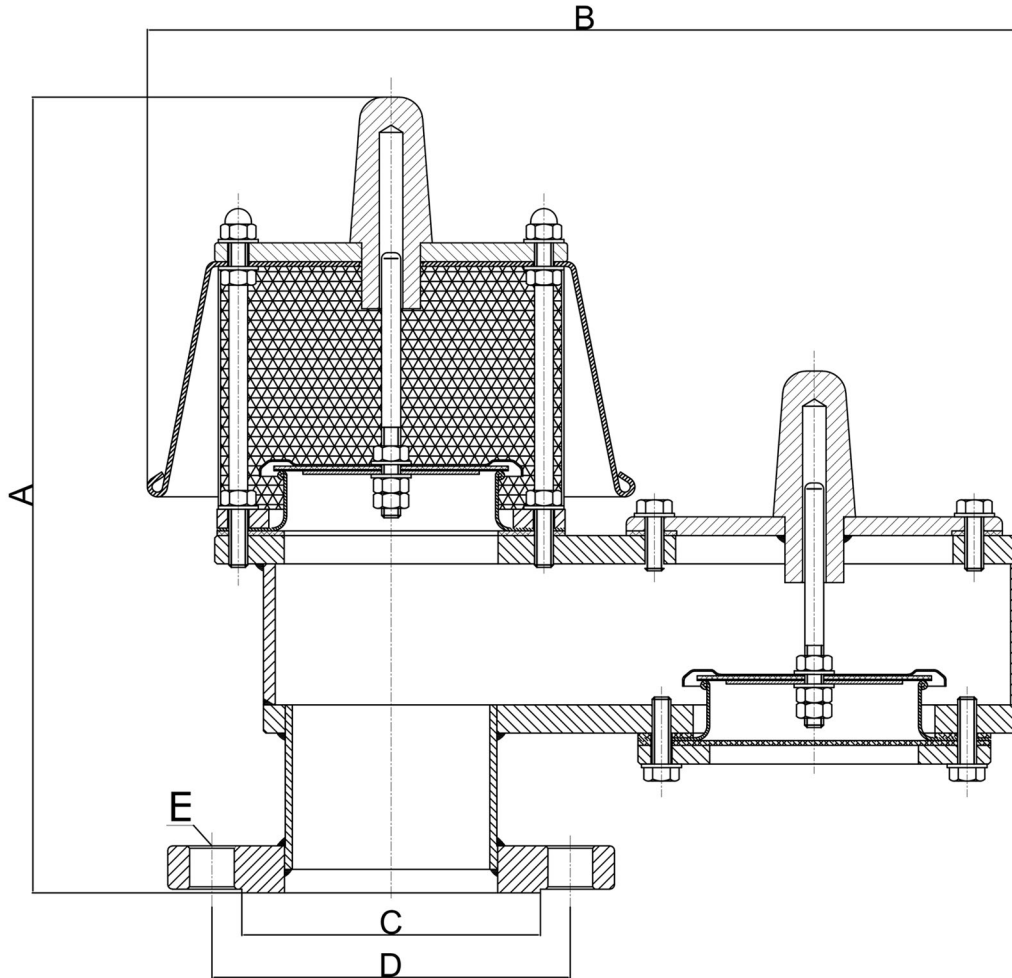

SIZE		A	B	C		D		E		Total Weight (kg)
NPS	DN			ANSI 150# RF	DN	ANSI 150# RF	DN	ANSI 150# RF	DN	
2"	50	317	270	Ø92.1	Ø102	Ø120.6	Ø125	Ø19x4	Ø18x4	12,5
3"	80	334	350	Ø127	Ø138	Ø152.4	Ø160	Ø19x4	Ø18x8	17
4"	100	418	475	Ø157.2	Ø158	Ø190.5	Ø180	Ø19x8	Ø18x8	24
6"	150	449	615	Ø215.9	Ø212	Ø241.3	Ø240	Ø22.2x8	Ø22x8	41
8"	200	494	807	Ø269.9	Ø268	Ø298.4	Ø295	Ø22.2x8	Ø22x12	70
10"	250	592	908	Ø323.8	Ø320	Ø362	Ø355	Ø25.4x12	Ø26x12	87
12"	300	630	1020	Ø381	Ø378	Ø431.8	Ø410	Ø25.4x12	Ø26x12	112

Flow Capacity Table

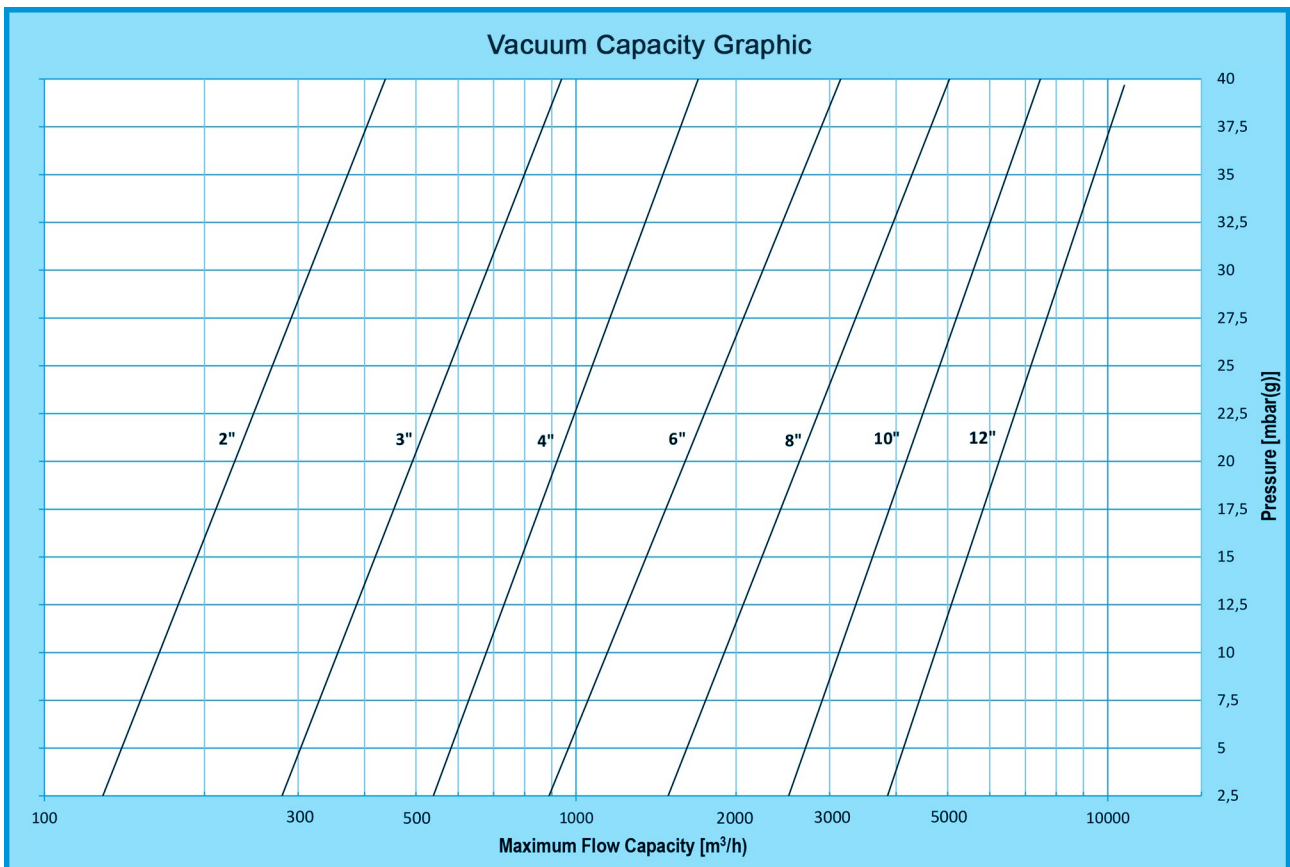
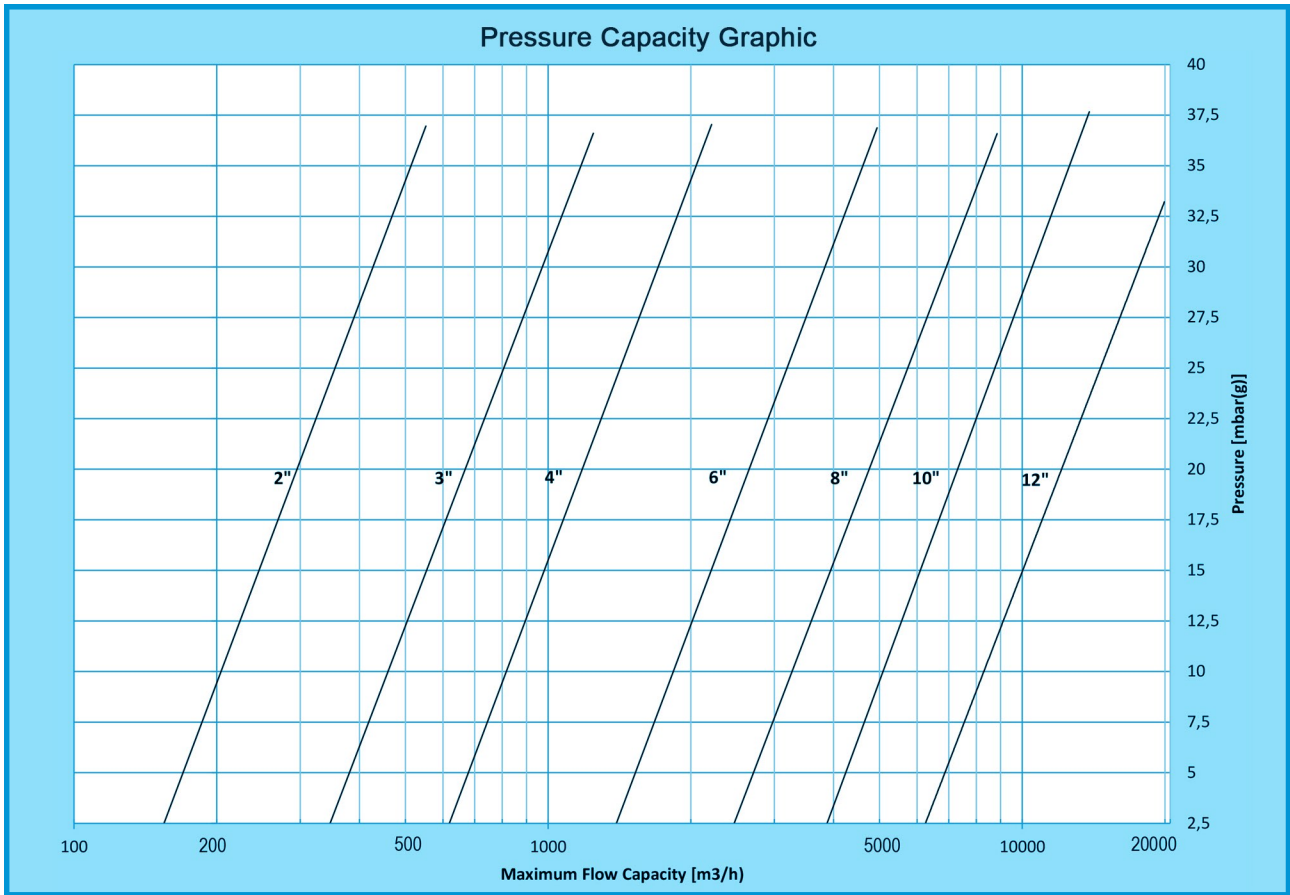

Flow Capacity Table

PRESSURE RELIEF CAPACITIES [m ³ /h] - OVERPRESSURE WEIGHTED														
mbar(g)	2"		3"		4"		6"		8"		10"		12"	
	20%	40%	20%	40%	20%	40%	20%	40%	20%	40%	20%	40%	20%	40%
2,5	150	163	339	367	603	653	1356	1468	2413	2613	3777	4089	5439	5888
5	213	230	480	519	853	924	1917	2076	3414	3696	5342	5783	7691	8326
7,5	275	297	620	671	1104	1195	2479	2683	4415	4779	6907	7478	9943	10764
10	302	327	679	735	1207	1306	2711	2935	4827	5225	7554	8177	10876	11774
12,5	329	356	738	799	1309	1417	2943	3186	5239	5671	8200	8877	11809	12784
15	356	386	797	863	1412	1528	3175	3437	5651	6117	8846	9577	13309	14408
17,5	384	415	856	926	1514	1639	3407	3689	6063	6563	9493	10277	14502	15700
20	426	461	960	1040	1706	1847	3812	4126	6823	7387	10678	11559	15374	16644
22,5	469	507	1065	1153	1898	2054	4216	4564	7584	8210	11862	12842	15940	17256
25	476	516	1070	1159	1906	2064	4285	4639	7628	8258	11936	12921	17178	18597
27,5	484	524	1076	1165	1915	2073	4353	4713	7671	8305	12009	13000	18417	19937
30	522	565	1176	1273	2088	2261	4692	5080	8355	9045	12201	13209	18824	20379

VACUUM RELIEF CAPACITIES [m ³ /h] - UNDERPRESSURE WEIGHTED														
mbar	2"		3"		4"		6"		8"		10"		12"	
	20%	40%	20%	40%	20%	40%	20%	40%	20%	40%	20%	40%	20%	40%
2,5	119	127	268	285	567	604	963	1026	1549	1651	2739	2918	3906	4161
5	182	194	347	369	653	695	1363	1452	2145	2286	3324	3542	4780	5092
7,5	245	261	426	454	706	752	1772	1888	2628	2800	3561	3794	5313	5660
10	254	270	505	538	777	828	2127	2266	3042	3241	3888	4143	5284	6024
12,5	262	279	550	586	936	998	2339	2492	3301	3517	4216	4492	5995	6387
15	286	304	593	632	1017	1083	2526	2692	3638	3876	4452	4744	6101	6955
17,5	309	329	658	701	1140	1214	2678	2853	4004	4266	4888	5208	7061	7523
20	361	384	708	755	1279	1363	2785	2967	4296	4577	5580	5945	7735	8818
22,5	412	439	768	819	1317	1403	2869	3056	4588	4888	6272	6683	9492	10113
25	398	424	817	871	1344	1431	2926	3117	4811	5125	6708	7147	9369	10681
27,5	384	409	861	918	1396	1488	2984	3180	5042	5372	7143	7611	10558	11248
30	439	467	910	969	1772	1888	3044	3243	5312	5659	7703	8207	11338	12080

YOU ARE ONE STEP CLOSER TO MAKE THE RIGHT CHOICE



We are focusing on our core business platforms to deliver **highest quality** critical industrial products for energy, chemical, water, marine, mining, and manufacturing markets to support our customers for rapidly changing challenges.



Confidence, based on almost **40 years of experience!**

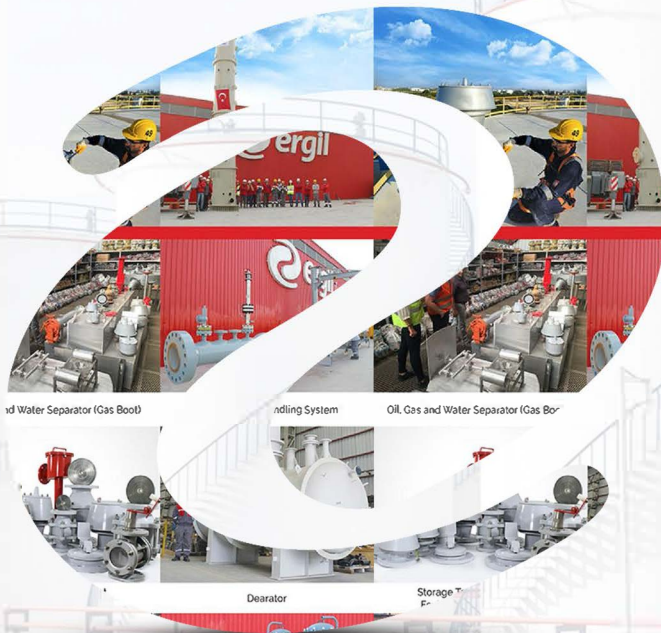

DO YOU NEED A
**QUOTATION,
SPARE PARTS,
MAINTENANCE?**

CLICK HERE TO OUR
"REQUEST TO QUOTE" FORM

TRUSTED BY PROFESSIONALS
IN 150 COUNTRIES



CALL US FOR FREE CONSULTATION

