

# Vacuum Relief Valve

End-of-line, weight loaded  
**Model 190**



## Product Description

Storagetech™ 's Model 190 Vacuum Relief Valve is designed to protect the tank from excessive under pressure during operation. The weighted-loaded pallet and diaphragm assembly is held tightly against a seal to prevent the loss of vapour to atmosphere in the closed position. As the internal pressure in the tank decreases, due to emptying or vacuum conditions occurs, the balance between the tank pressure and the external atmospheric pressure changes, accordingly when the set pressure of the unit is reached, the diaphragm opens to vacuum air content and rebalance the internal pressure. Model 190 set vacuum can be arranged as per storage tank requirements and the valve will reseal when internal pressure returns to below set pressure. The vent will close when the tank returns to a positive pressure. A mesh filter screen over the air inlet port prevents the ingress of atmospheric pollution. Storagetech Valves Activated as close as to set pressures, less than 10% of set pressures, ensuring accurate pressure management and isolate emission losses perfectly .

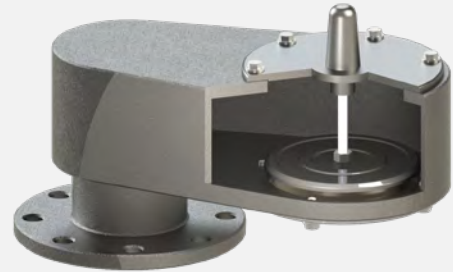

With 40 years of experience, Storagetech™ PVV systems offer effective solutions against unwanted evaporation and vacuums that may occur in tanks.

Thanks to PVV solutions produced completely in accordance with international norms, Storagetech™ is a reliable, sustainable and effective solution partner for your investments.

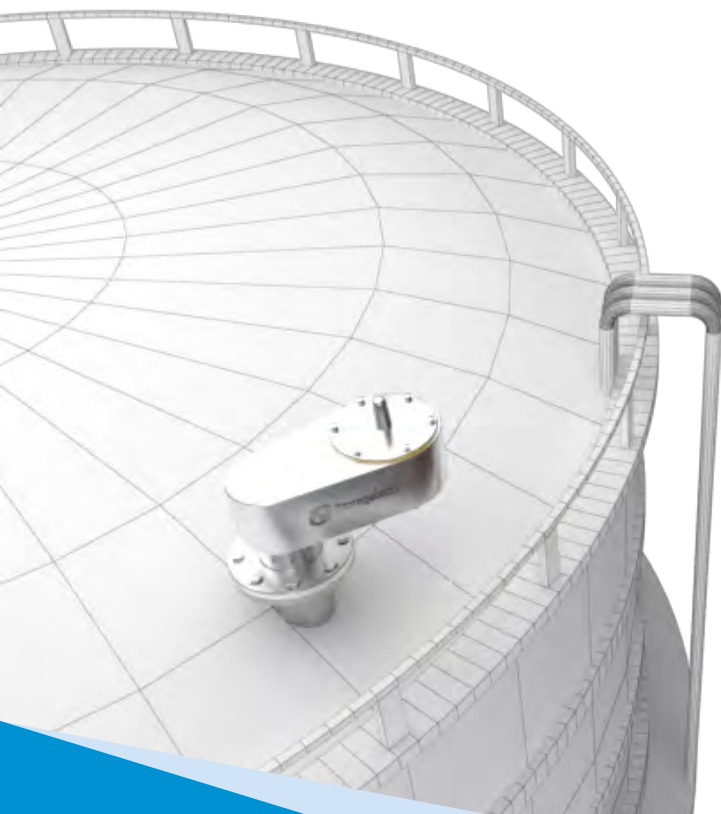

<b>Standard Sizes</b>	2" to 12" (DN50 to DN300) Further sizes are applicable upon request.
<b>Flanges</b>	ANSI, DIN, JIS, BSP
<b>Body</b>	Carbon Steel, Stainless Steel or Aluminium
<b>Seals</b>	Klingrit, Nitrile, Viton, PTFE
<b>Pallet</b>	Stainless Steel AISI 304/316
<b>Springs</b>	Stainless Steel
<b>Paint Finish</b>	1.Customer Specification 2.Powder Coating, Colour RAL 9006 3.Epoxy Paint, Colour RAL 9006 4. PTFE Coating
<b>ATEX Cert</b>	Ex II 1/2 G Ex h IIB Ga/Gb

## Setting Range

**Vacuum** Weight-loaded +3.5 mbar and +35 mbar. (+1,4 inch W.C and +14 inch W.C)

\*Different settings can be applicable as per request.

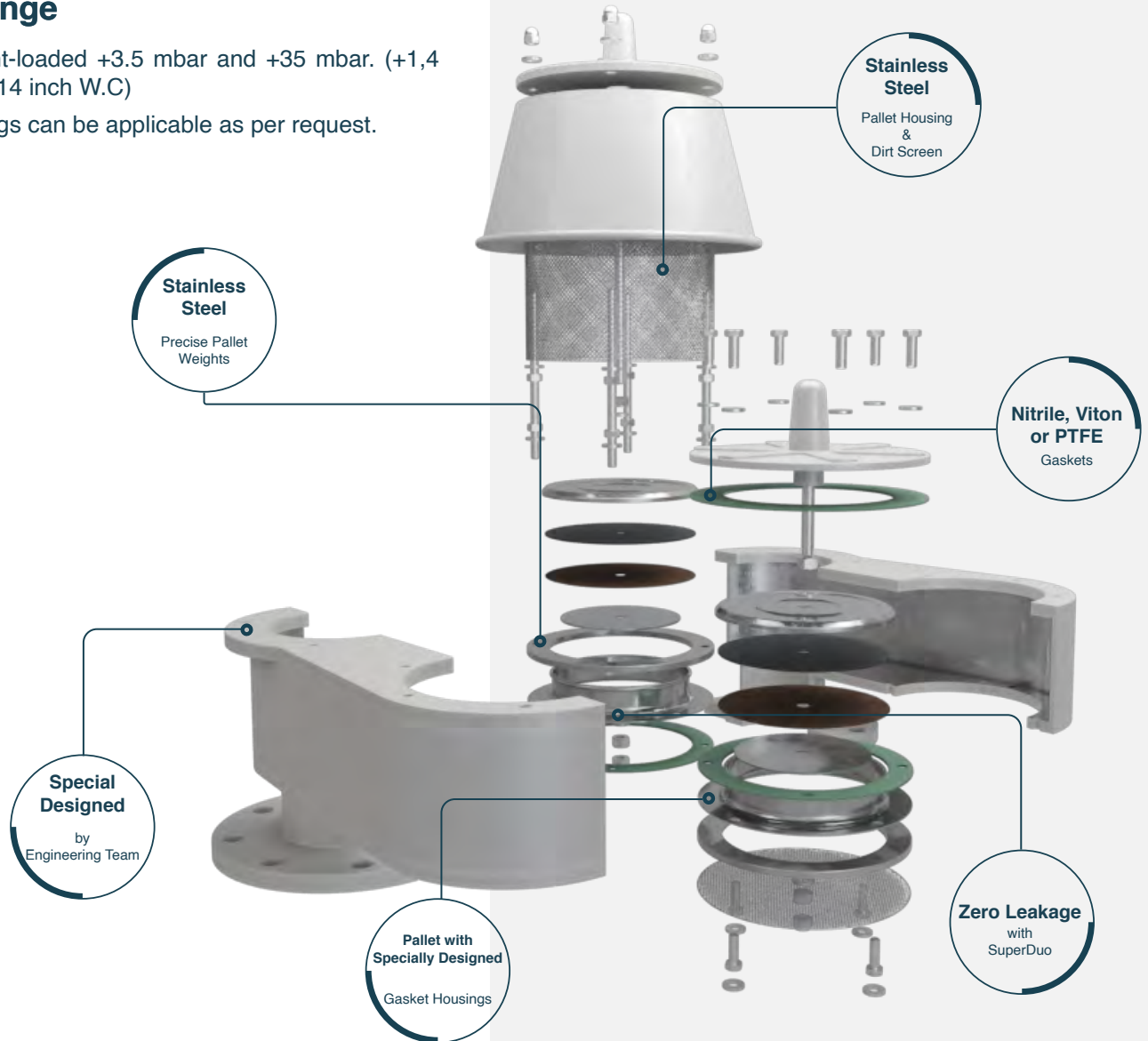

## Key Features

- Easy to install. Do not need a special tool or experience.
- Transferring vapour content to collection system or condensation units.
- Prevent certain fire hazards.
- Light weight construction.
- Quick and easy to install, inspect and clean.
- Any grade materials are available.
- Has stainless steel pallets.
- Special designs can be achievable upon request to meet individual specifications.
- Eliminate the intake of air content (if needed) and the escape of vapors.
- Internal materials are resistant to winter conditions.
- Vacuum and relief cases can be managed effectively as per the set requirements of bulk storage tank.

- Super Duo technology provides extra curves and perfect seating with zero leakage.
- Set values can be arranged as per the site conditions, no need supervising.
- Design, manufacturing and test according to EN ISO 80079-36.
- PTFE, XYLAN, Rubber lining, etc. coating options are available.
- ANSI, DIN, JIS, API, etc. any special end connections are available.
- Breathing requirements are fulfilled according to API 2000 7th Edition.
- Diaphragm is manufactured from PTFE material to prevent possibility of ice formation and sticky residues hindering the valve from opening, while the pallet assembly moves freely on guide posts.

## Technical Drawing

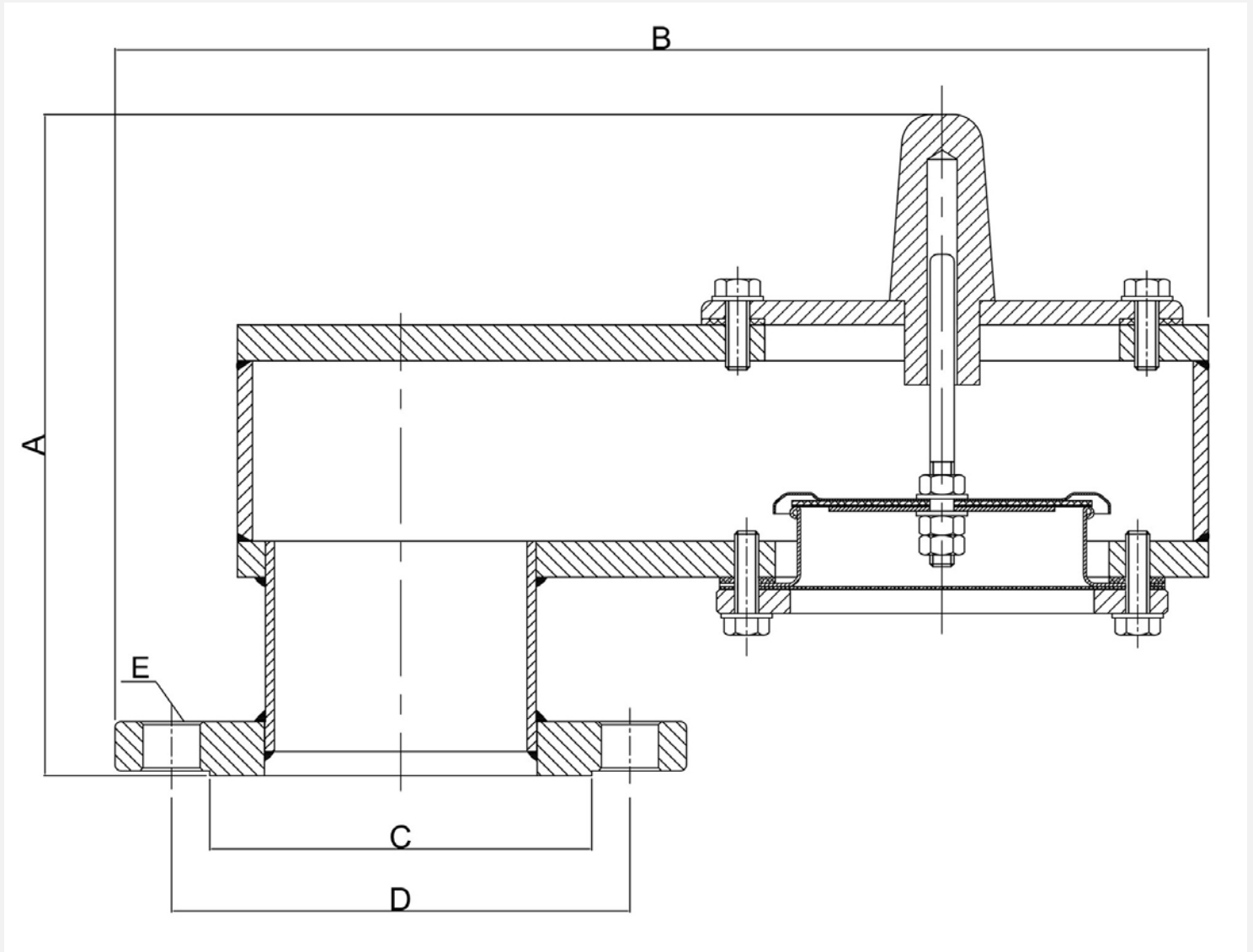

## Weight & Dimensions

SIZE		A	B	C		D		E		TOTAL WEIGHT (kg)
NPS	DN			ANSI 150# RF	DN	ANSI 150# RF	DN	ANSI 150# RF	DN	
2"	50	200	271	Ø92.1	Ø102	Ø120.6	Ø125	Ø19x4	Ø18x4	8
3"	80	219	349	Ø127	Ø138	Ø152.4	Ø160	Ø19x4	Ø18x8	14
4"	100	280	446	Ø157.2	Ø158	Ø190.5	Ø180	Ø19x8	Ø18x8	21
6"	150	282	616	Ø215.9	Ø212	Ø241.3	Ø240	Ø22.2x8	Ø22x8	29
8"	200	329	751	Ø269.9	Ø268	Ø298.4	Ø295	Ø22.2x12	Ø22x12	55
10"	250	405	871	Ø323.8	Ø320	Ø362	Ø355	Ø25.4x12	Ø26x12	73
12"	300	441	997	Ø381	Ø378	Ø431.8	Ø410	Ø25.4x12	Ø26x12	107

## Flow Capacity Tables

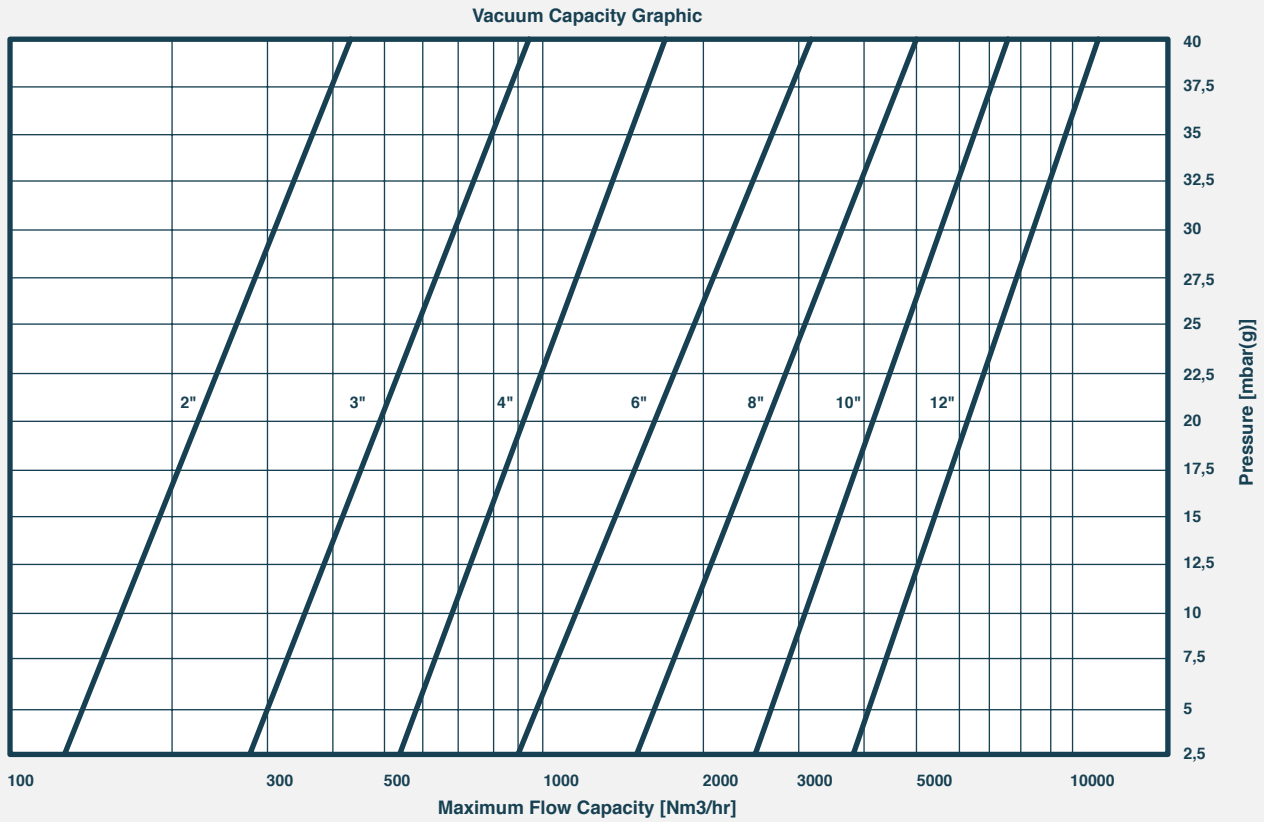

### VACUUM RELIEF CAPACITIES [Nm3/hr] - UNDERPRESSURE WEIGHTED

mbar	2"		3"		4"		6"		8"		10"		12"	
	20%	40%	20%	40%	20%	40%	20%	40%	20%	40%	20%	40%	20%	40%
2,5	119	127	268	285	567	604	963	1026	1549	1651	2739	2918	3906	4161
5	182	194	347	369	653	695	1363	1452	2145	2286	3324	3542	4780	5092
7,5	245	261	426	454	706	752	1772	1888	2628	2800	3561	3794	5313	5660
10	254	270	505	538	777	828	2127	2266	3042	3241	3888	4143	5284	6024
12,5	262	279	550	586	936	998	2339	2492	3301	3517	4216	4492	5995	6387
15	286	304	593	632	1017	1083	2526	2692	3638	3876	4452	4744	6101	6955
17,5	309	329	658	701	1140	1214	2678	2853	4004	4266	4888	5208	7061	7523
20	361	384	708	755	1279	1363	2785	2967	4296	4577	5580	5945	7735	8818
22,5	412	439	768	819	1317	1403	2869	3056	4588	4888	6272	6683	9492	10113
25	398	424	817	871	1344	1431	2926	3117	4811	5125	6708	7147	9369	10681
27,5	384	409	861	918	1396	1488	2984	3180	5042	5372	7143	7611	10558	11248
30	439	467	910	969	1772	1888	3044	3243	5312	5659	7703	8207	11338	12080

# Product Recommendations



## Flame Arrestor

End-Of-Line,  
With Automatic  
Opening Hood,  
Deflagration

### Model: 312

Storagetech™ Flame Arrestors ( End-of-line, with Automatic Opening Hood) are passive devices that prevent the propagation of a flame or fire from entering into an opening in a pipeline or vessel discharging flammable vapor. As different from model 310, Model 312 end of line flame arrester's weather hood is designed to react fire instantly tanks to it's fusible link, which is melted during the fire and let the weather hood release the gas/fire to the atmosphere.

## Pressure Vacuum Relief Valve With Flame Arrestor



End-Of-Line,  
Weight Loaded,  
Combination,  
Atmospheric Deflagration  
Proof

### Model: 330

Storagetech™'s Model 330 Pressure Vacuum Relief Valve with Flame Arrestor provides protection to bulk storage tanks and vessels from over and under pressurization.



## Flame Arrestor

Vertical,  
In-Line,  
Detonation

### Model: 320

Storagetech™'s Model 320 In-line Detonation Flame Arrestor (also called flame arrester or fire arrester) is designed for installation in gas pipelines. Detonation occurs when a flame travelling through the pipeline reaches supersonic velocities, usually as a result of the pipeline configuration or pipeline surface roughness. Changes in gas density and pressure causes the flame velocity to metamorphose from subsonic to supersonic.



## Flame Arrestor

Horizontal,  
In-Line,  
Detonation

### Model: 321

Storagetech™'s Model 321 In-line Detonation Flame Arrestor (also called flame arrester or fire arrester) is designed for installation in gas pipelines. Detonation occurs when a flame travelling through the pipeline reaches supersonic velocities, usually as a result of the pipeline configuration or pipeline surface roughness. Changes in gas density and pressure causes the flame velocity to metamorphose from subsonic to supersonic.



## Äger GmbH

### Germany Head Office + R&D + Sales

Herzogspitalstraße 24  
Munich 80331  
Germany  
+49 89 9040 5200  
www.aager.de  
sales@aager.de

### Turkey Head Office + Sales

Ağaoğlu My Office 212  
No: 3 B Blok /175  
P.K 34218 Güneşli – Bağcılar  
Istanbul / Turkey  
+90 212 485 40 07  
+90 212 485 40 42  
www.ergil.com  
sales@ergil.com

### Turkey Factory + Engineering + R&D + Sales

Mersin Tarsus OSB.13.CD.NO:7  
P.K: 33540 Mersin, Turkey  
+90 324 676 44 04  
+90 324 676 44 03  
sales@ergil.com

### U.A.E. Sales + Warehouse

Jumeirah Lake Towers, X2 Tower 1906  
P.O. Box: 123661 Dubai, U.A.E.  
+971 4 450 8051  
+971 4 450 8041  
sales@ergil.com

### data sheet series

VRV - End-of-line,  
weight loaded

Revision No: 02  
ST-DS-VR.EOL.W-04.21/V2  
storagetech.de

April 2021

Storagetech™ Website  
QR Code

